

# Front Loader Washing Machine, 12kg

Series 7 | Front Load

White



With room for large loads, this front loader has a cycle for any kind of load, from delicates to bulky items.

- With 13 wash cycles including a 30 minute Quick cycle to cater to busy lives
- Add a Garment function allows you to add items mid cycle
- Auto-dosing ensures the right amount of detergent is dispensed for the level of soil detected
- 4.5 star water and energy rating

## DIMENSIONS

|        |        |
|--------|--------|
| Height | 850 mm |
| Width  | 600 mm |
| Depth  | 665 mm |

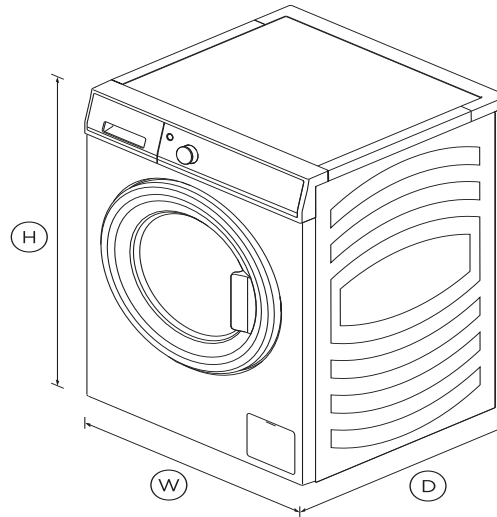

## FEATURES & BENEFITS

### 13 fabric care cycles

With 13 fabric care cycles including Quick, Bulky and Handwash. The specially-designed cushioned drum provides a gentle, effective washing action, protecting clothes while delivering an optimal wash performance.

### SmartDrive™ technology

SmartDrive™ Technology is a gentle, quiet, and efficient combination of smart electronics and a direct drive motor that senses the load, to deliver better fabric care.

Quick cycles

When time is short, you can select a quick 30 minute wash without compromising cleaning and fabric care. Vortex Wash allows most cycles to take less than 1 hour to complete. Water is forced from the bottom of the drum, so detergent and heat reach your clothes faster, cleaning quickly and avoiding over-washing.

### Wash larger loads

The large 12kg drum can wash both small and large loads as well as bulky items like a king size feather doona. The wide door opening makes it easy to load and unload. Large capacity is time saving, as a full week's laundry can be done in just a few loads. Accurate water level sensing makes it highly efficient at washing different load sizes.

### Add a Garment

Clearly labelled compartments make it easy to see where to put washing powder and softener. It is cleverly shaped to minimise spills and is easy to remove and clean.

### Designed to match

The complete package for a beautiful laundry. The 12kg washing machine is designed to match our 9kg Heat Pump Condensing Dryer or 8kg Condensing Dryer. With outstanding aesthetics and complementary wash and dry cycles, they become the perfect pair to deliver complete fabric care.

## SPECIFICATIONS

### Accessories

Stacking kit

### Capacity

Capacity **12kg**

### Consumption

Energy rating **4.5 star**

| <b>Features</b>                |                       |
|--------------------------------|-----------------------|
| Add a garment (immediate)      | •                     |
| Anti-fungal door gasket        | •                     |
| Auto out of balance correction | •                     |
| Automatic Water Level          | •                     |
| Choice of cold only or hot and | •                     |
| Customise cycle                | •                     |
| Delay start                    | •                     |
| Eco                            | •                     |
| Excess foam detection          | •                     |
| Extra large door               | •                     |
| Extra rinse option             | •                     |
| Flood protection               | •                     |
| Keylock                        | •                     |
| Pre Wash                       | •                     |
| Progress indicator             | •                     |
| Smart Diagnosis of problems    | •                     |
| SmartTouch™ control dial       | •                     |
| Soil levels                    | <b>3</b>              |
| Stainless steel drum bowl      | •                     |
| Time to go                     | •                     |
| Timed liquid detergent         | •                     |
| Water supply                   | <b>Hot &amp; Cold</b> |
| Water temperature controls     | <b>5</b>              |
| Wrinkle Free                   | •                     |
| <b>Performance</b>             |                       |
| Maximum spin speed             | <b>1400rpm</b>        |
| Number of spin speeds          | <b>4</b>              |

|                        |           |
|------------------------|-----------|
| Number of wash cycles  | <b>13</b> |
| SmartDrive™ technology | •         |
| Vortex™ Wash           | •         |

**Product dimensions**

|        |               |
|--------|---------------|
| Depth  | <b>665 mm</b> |
| Height | <b>850 mm</b> |
| Width  | <b>600 mm</b> |

**Warranty**

|                              |                 |
|------------------------------|-----------------|
| Parts and labour             | <b>2 years</b>  |
| Parts only SmartDrive™ Motor | <b>10 years</b> |

**Wash Cycles**

|                       |           |
|-----------------------|-----------|
| Allergy               | •         |
| Bulky                 | •         |
| Cottons               | •         |
| Delicate              | •         |
| Drum Clean            | •         |
| Easy Iron             | •         |
| Everyday              | •         |
| Handwash              | •         |
| Heavy                 | •         |
| Number of wash cycles | <b>13</b> |
| Quick                 | •         |
| Rinse                 | •         |
| Spin                  | •         |
| Super Quick           | •         |

SKU **93237**

The product dimensions and specifications in this page apply to the specific product and model. Under our policy of continuous improvement, these dimensions and specifications may change at any time. You should therefore check with Fisher & Paykel's Customer Care Centre to ensure this page correctly describes the model currently available. Â© Fisher & Paykel Appliances Ltd 2019.

---

Other product downloads available at [fisherpaykel.com](http://fisherpaykel.com)



User Guide



Warning Label



Service & Warranty Booklet



Installation Guide (Cavity Sizes)



Installation Guide



**A PEACE OF MIND SALE**

**24 Hours 7 Days a Week Customer Support**

**T 1300 650 590 W [www.fisherpaykel.com](http://www.fisherpaykel.com)**