

SLTC919 L 850
85CM UNDERMOUNT HOOD



let's get
Sirius
 with rangehood design



SLTC919 L 850

Features and Benefits:

UNDERMOUNT DESIGN	Streamline, modern and unobtrusive design, potentially allows greater use of cupboard space above hob- Fits into Standard 300mm cabinetry
LED LIGHTS	Energy efficient, Better illumination of cooking area, Longer life span than standard globes or Halogen, Modern aesthetic
COMMERCIAL STAINLESS STEEL BAFFLE FILTERS	Commercial design, Dishwasher safe, Designed for greatest air movement for maximum performance, Easy to fit and remove, Lifetime filters: last the life of the hood
INDUCTION COUNTDOWN CONTROL	10 minute auto function used at the end of cooking to reduce condensation build up common to induction cooking. 'C' shaped baffles eliminates moisture dripping onto cooking surface
LARGER DUCTING DIAMETER	Greater extraction and lower dB rating due to less air flow restriction
CLEAN FILTER INDICATOR	Takes the guessing game out of maintaining your hood
ELECTRONIC CONTROL	Easy to use touch control on fold-out glass fascia
MADE IN ITALY	Units are designed specifically for the Australian market and manufactured in Italy by dedicated boutique specialist manufacturer
WARRANTY	Warranty is 6 years when Sirius ducting is used. Sirius strongly recommend to use the correct ducting as to not void warranty and to achieve the ideal result

Distributed by Arisit Pty Ltd

40-44 Mark Anthony Drive, Dandenong South VIC 3175 Ph: 1300 762 219 Fax: 03 9768 0838 Website: www.arisit.com

SLTC919 L 850

85CM UNDERMOUNT HOOD



let's get
Sirius
with rangehood design

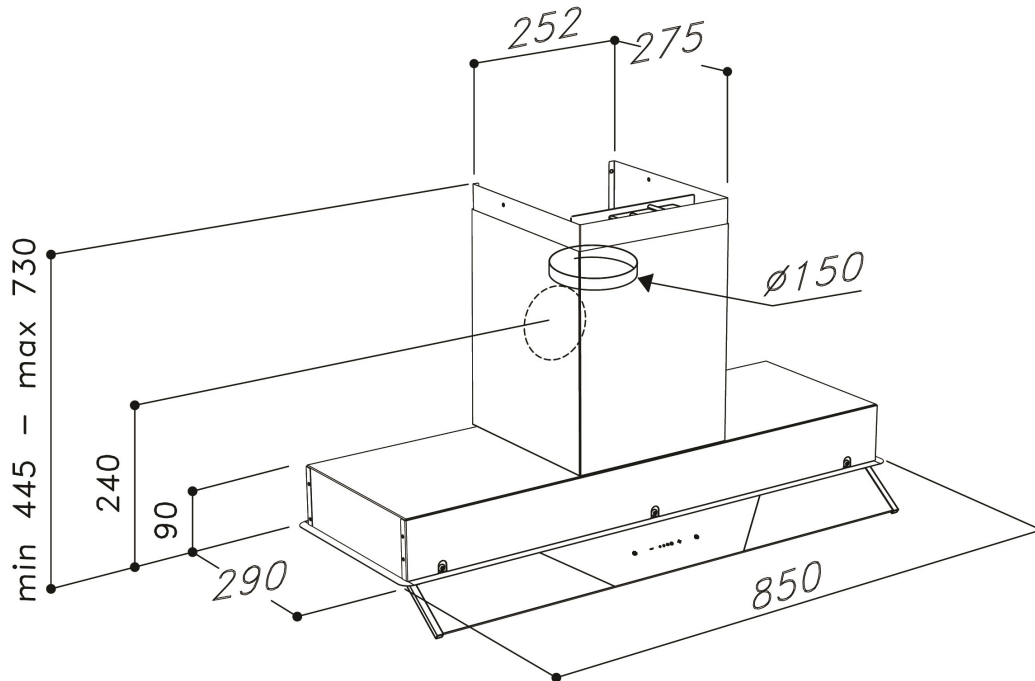

Rectangular opening: 265mm x 835mm (SLTC919 L 850)

Technical Specifications:

MODEL	SLTC919 L 850
CONTROL PANEL	ELECTRONIC TOUCH CONTROL on GLASS FASCIA
MOTOR	SINGLE ALUMINIUM
EXTRACTION	1020m ³ /h
DUCTING DIAMETER	150mm
LIGHTS	6w strip LED Lighting
FILTER	STAINLESS STEEL BAFFLE
ELECTRICAL REQUIREMENT	10A
PRODUCT DIMENSIONS	(W) 850mm x (D) 290mm x (H) 445-730mm
WARRANTY	3 YEARS (6 YEARS WHEN SIRIUS DUCTING IS USED)

WARNING: technical specifications and product sizes can be varied by the manufacturer, without notice. Cut outs for appliances should only be by physical product measurements. The above information is indicative only.

Distributed by Arisit Pty Ltd

40-44 Mark Anthony Drive, Dandenong South VIC 3175 Ph: 1300 762 219 Fax: 03 9768 0838 Website: www.arisit.com