

SRI300BM INTEGRATED REFRIGERATOR AND FREEZER



EAN 8690842059728

Finish	White
Dimensions	556mmW x 545mmD x 1777mmH
Gross Capacity	Refrigerator: 172L (net) Freezer: 65L (net) Total: 300L (gross)

Refrigerator

No. Shelves	4 x shelves
No. Drawers	2 x drawers
No. Door Shelves	3 x door racks
Lighting	1 x top light
Accessories	1 x ice tray egg rack (10 eggs) tube tray

Freezer

No. Drawers	3 x freezer drawers
Defrost	Frost Free

Features

Installation	built-in integrated, freezer or bottom, fixed mounting cover door installation
--------------	--------------------------------------------------------------------------------

Performance

Energy Consumption	385 KWH/year
Star Rating	2.5
Power	230 - 240V 50/60Hz 100W 10A

Warranty	Two years parts and labour
----------	----------------------------



ID190222

SRI300BM INTEGRATED REFRIGERATOR AND FREEZER

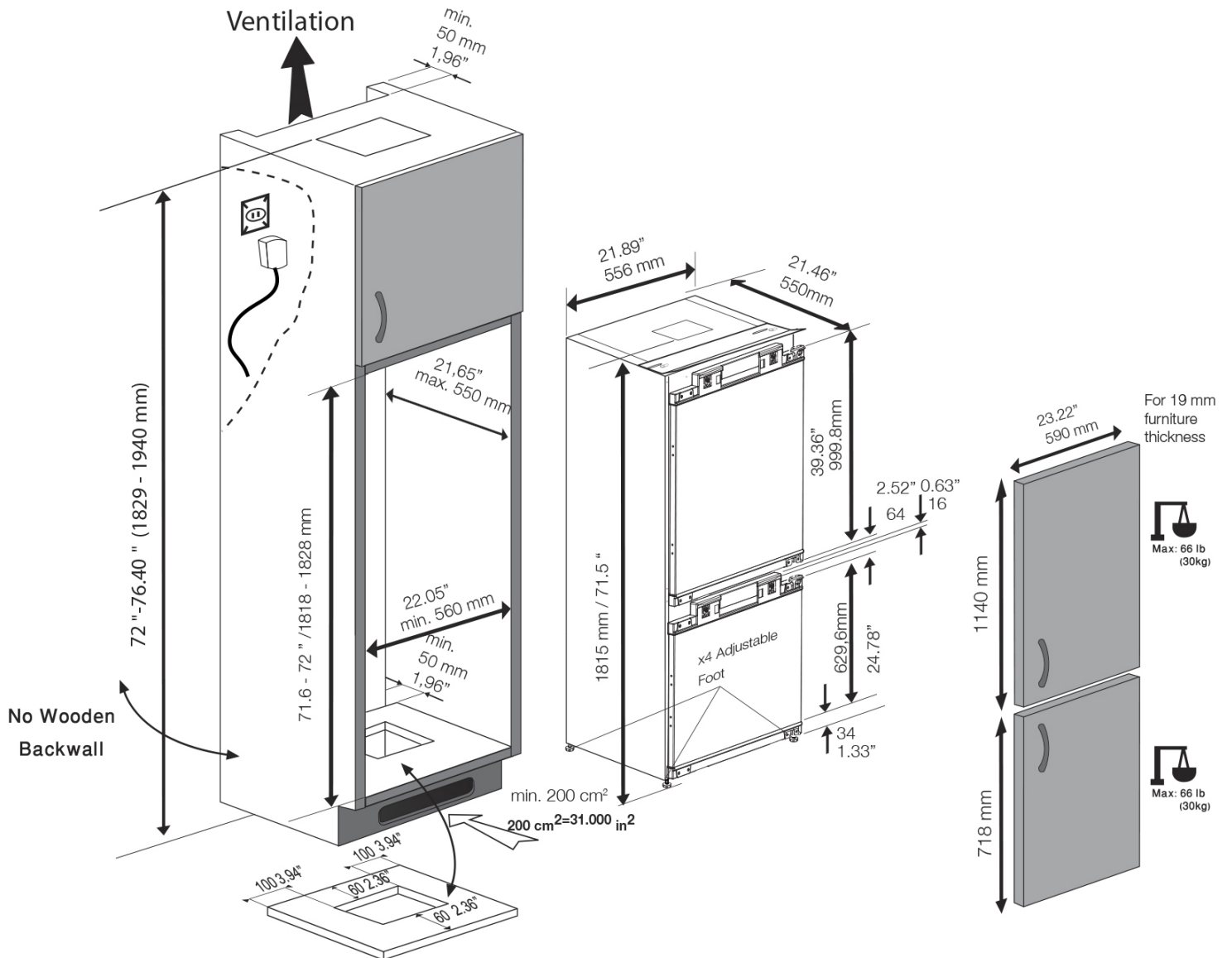

PLEASE NOTE: drawings are not to scale. They are to assist only.
 WARNING: technical specifications and product sizes can be varied by the manufacturer without notice.
 Cutouts for appliances should only be by physical product measurements. The above information is indicative only.