



DA 2578

Extractor unit
with energy-efficient LED lighting and light-touch
switches for easy use.

- Customised kitchen design – fully integrated in 702mm width
- Unique user convenience – Con@ctivity ⓘ
- Powerful – 785m³/h on the booster setting
- Efficient filtration – 10-layer stainless-steel grease filter ⓘ
- Safe and easy to clean – Miele CleanCover ⓘ



DA 2578

Installation drawings

Whether you want to replace a household appliance or planning a kitchen - here you will find all the relevant installation diagrams for your Miele appliance.

If you want to download an installation diagram, please click on the appropriate image and the high-resolution version is displayed. To download, click the right mouse button and save the image on your computer.

Please note that the installation and maintenance of our equipment should only be performed by a licensed contractor. For questions, please call us and we will advise you without any obligation!

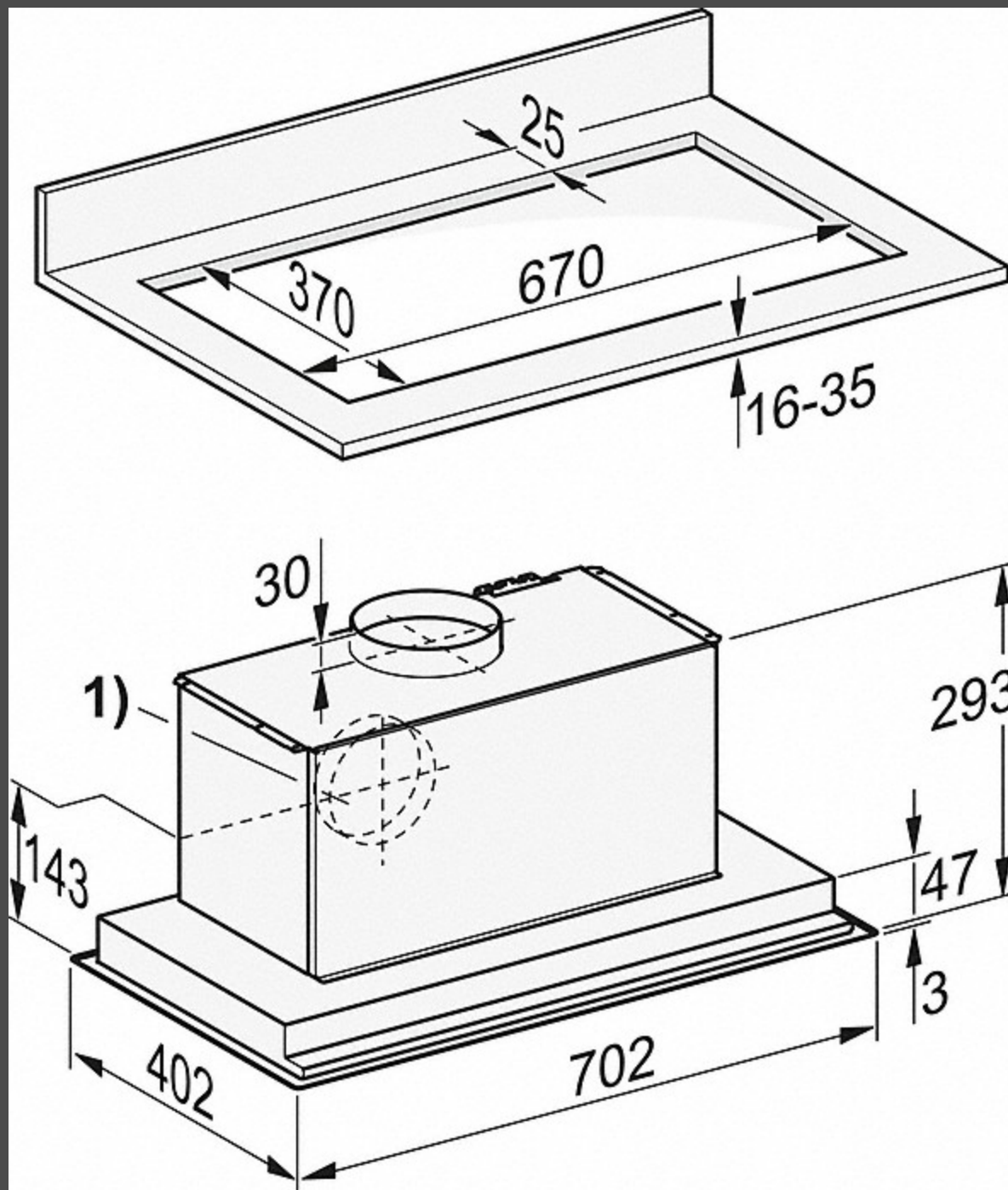

DA 2578

Product details - DA 2578

Construction type

Integrated extractor -

Design

Colour Stainless steel

RAL colours available as customisation on request -

Customisation possible on request -

Operating modes

Type of air guide Convertible

Active charcoal filter (order separately) DKF15-1

User convenience

Electronic controls -

Light-touch controls -

Miele@mobile app -

Power levels (number without Booster level) 3

Booster level -

Programmable Booster level switch-off -

Run-on time 5 / 15 min. - ⓘ

Grease filter saturation indicator programmable - ⓘ

Active charcoal filter saturation indicator programmable - ⓘ

Cleaning convenience

CleanCover - ⓘ

Air throughput in recirculation mode

Air throughput in Level 1 (m³/h)	250
Air throughput in Level 2 (m³/h)	375
Air throughput in Level 3 (m³/h)	500
Air throughput in Booster level (m³/h)	625
Sound power in Level 1 (dB(A) re 1 pW)	59
Sound power in Level 2 (dB(A) re 1 pW)	65
Sound power in Level 3 (dB(A) re 1 pW)	70
Sound power in Booster level (dB(A) re 1 pW)	74
Sound pressure in Level 1 (dB(A) re 20 µPa)	46
Sound pressure in Level 2 (dB(A) re 20 µPa)	52
Sound pressure in Level 3 (dB(A) re 20 µPa)	57
Sound power in Booster level (dB(A) re 1 pW)	61

Safety

Safety switch-off - ⓘ

Technical data

Canopy width in mm	702
Canopy height in mm	50
Canopy depth in mm	402
Net weight in kg	11.6
Length of supply lead in m	1.5
Standard plug fitted	-
Total rated load in kW	0.30
Voltage in V	230
Fuse rating in A	10
Number of phases	1

Installation notes

Extraction ducting connection at top	-
Extraction connection at top and rear	-
Diameter of extraction ducting connection in mm	150

Appliance networking

Miele@home	- ⓘ
WiFiConn@ct	- ⓘ
MobileControl	- ⓘ
ShopConn@ct	- ⓘ
Automatic function Con@ctivity 2.0 (Zigbee)	- ⓘ
Automatic function Con@ctivity 3.0 (WiFi)	- ⓘ

Filter system

Number of dishwasher-safe stainless steel grease filters ⓘ 2

Lighting

LED	-
Light intensity in Lx	300
Colour temperature in K	3,000

Fan

Dual-action fan	- ⓘ
AC motor	-

Air throughput with max. duct diameter in extraction mode (not for external version)

Air throughput in Level 1 (m³/h)	290
Air throughput in Level 2 (m³/h)	425
Air throughput in Level 3 (m³/h)	575
Air throughput in Booster level (m³/h)	785
Sound power in Level 1 (dB(A) re 1 pW)	48
Sound power in Level 2 (dB(A) re 1 pW)	55
Sound power in Level 3 (dB(A) re 1 pW)	63
Sound power in Booster level (dB(A) re 1 pW)	70
Sound pressure in Level 1 (dB(A) re 20 µPa)	35
Sound pressure in Level 2 (dB(A) re 20 µPa)	42
Sound pressure in Level 3 (dB(A) re 20 µPa)	50
Sound pressure in Booster level (dB(A) re 20 µPa)	57

Standard accessories

Non-return flap	- ⓘ
Adapter to reduce ducting diameter from 150 mm to 125 mm Ø	-
RF Con@ctivity 2.0 communication stick for KM	XKS 3000 Z