



RVY497190

ACLETHRF10:

Ethylene absorber refill kit

ACLETHST10:

Ethylene absorber starter kit

RA430100:

Storage container with lid, anthracite

RA450012:

Water filter Vario 400

RVA438040:

Bottle support, oak wood, 1 pcs.

RVA450220:

Activated charcoal air filter, 2 pcs

RA425110:

Vario SS handle 1131 mm

RA425910:

Vario SS handle 810 mm

RA460030:

Frontpanel connection for RB

RVA421922:

SS door with handle, 90.0 cm for RVY497

RVA423141:

Side trims, 3 mm

RVA428922:

SS door w/o handle 90.0 cm for RVY497

RVA460000:

Installationskit side-by-side

RVA460020:

Backward compatibility kit SbS

RVA460900:

Replacement kit SbS, 91.4 cm/36"

RVA460910:

Replacement kit single unit, 91.4 cm/36"

Fridge-freezer combination 400 series

212.3 x 89.4 cm, soft close flat hinge

RVY497190

- Professional freshness system with five different climate zones
- Dark brushed stainless steel interior, refined with solid anthracite aluminium elements
- Warm white and glare-free LED light concept for optimal food presentation
- Spacious freezing compartment with integrated ice maker
- Guided interaction via intuitive touch display
- Dark brushed stainless steel interior, refined with solid anthracite aluminium elements

Warm white and glare-free LED light concept for optimal food presentation in all compartments

Opening assist for door enabling seamless integration without handles

Flat dark brushed stainless steel inner door

Flexible positioning of shelves and door racks through hidden rail system

Solid anthracite aluminium door racks

Professional freshness system with 2 fresh climate drawers and 1 chilled drawer

Integrated ice maker with fixed water connection

Spacious, fully extendable freezer compartment including 2 additional interior drawers

Full touch TFT display

Total volume 576 litres

Handling

Opening assist for door.

Cushioned door closing system.

Light and display response to drawer interaction.

Automatic brightness adjustment based on ambient illumination.

Easy accessible full touch TFT display.

Animated quick guides to assist appliance operation.

Technical Features

Dynamic cold air distribution.

Automatic defrosting with defrost water evaporation.

Constant air purification by 2 activated charcoal air filters.

Rest mode certified by Star-K.

Open-door and malfunction alarm.

Selected digital services (Gaggenau Home Connect)

Storage management with cameras.

Automatic programme selection of fresh climate drawers (via object recognition).

Personalisation function for saving custom programmes.

Remote control and monitoring.

Cooling

Professional freshness system.

No-Frost technology with fast cooling.

Temperature adjustable from +2 °C to +8 °C.

3 aluminium-framed safety glass shelves, individually adjustable in height.

1 integrated safety glass shelf.

Optimal food presentation with warm white and glare-free, hidden LED light bars (3000 K).

Flexible positioning of door racks through hidden rail system.

6 door racks, thereof 4 height adjustable.

Total volume of all refrigerator compartments:

379 litres.

Fresh climate drawer

2 fresh climate drawers with humidity control.

Temperature adjustable from -1 °C to +2 °C.

Ideal storage conditions for different foods through dedicated programmes (e.g. Fruit, Vegetables, Meat).

Individual adjustment of temperature and humidity.

Extended food preservation with ethylene absorber.

Indirect illumination, transparent front.

Fully extendable, with cushioned closing system.

Chilled drawer

Temperature dependent on cooling compartment (always 2K to 3K lower).

Indirect illumination, transparent front.

Fully extendable, with cushioned closing system.

Freezing

No-frost technology with fast freezing at -30 °C.

4-star freezer compartment.

Temperature adjustable from -24 °C to -16 °C.

Freezer burn protection.

Oxidation protection.

Freezing capacity 14 kg /24 h.

Storage time after a malfunction 19 h.

Spacious, fully extendable freezer compartment with synchronously running pull-out rails.

2 extendable interior drawers.

Warm-white, glare-free LED lighting (3000 K) within freezer compartment.

Total volume of freezer compartment: 197 litres.

Ice maker

Integrated in the freezer compartment, with fixed inlet water connection.

Can be switched off.

Particle filter for water inlet, integrated in ventilation grill area.

Saturation indicator for filter via full touch TFT display

Ice cube production: approx. 3 kg /24 h.

Removable ice storage container with approx. 3 kg capacity.

Integrated, easy accessible ice cube scoop.

Consumption data

Energy label grade RAP & HK: 5 Stars (AU)

AU Annual energy consumption: 354 kWh.

Noise level 39 dB (A) re 1 pW.

Planning notes

Flat hinge.

Door opening angle of 115°, fixable at 90°.

Max. door panel weight:

Each door 64 kg. Drawer 14 kg.

When rest mode is active, the appliance can only be opened using a handle.

Shut-off valve for water connection must be planned next to the appliance and always be accessible.

Shut-off valve for water connection must be planned next to the appliance and always be accessible.

If the water pressure exceeds 0.8 MPa (8 bar), connect pressure relief valve between water tap and hose set.

Connection

RVY497190

Total connected load 0.200 KW.

Connecting cable 3.0 m, detachable.

Water inlet.

Supply hose 2.8 m with 3/4" connection.

Water pressure 2 bar to 8 bar.

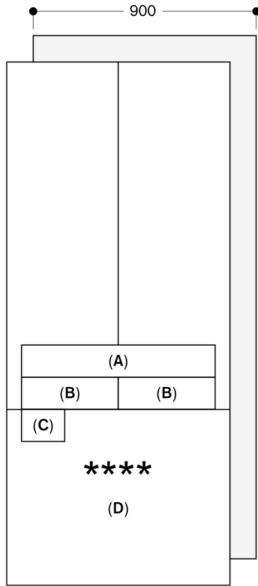

- A: Chilled drawer
- B: Fresh climate drawer
- C: Ice maker
- D: Drawer

Measurements in mm

Niche width 900 mm

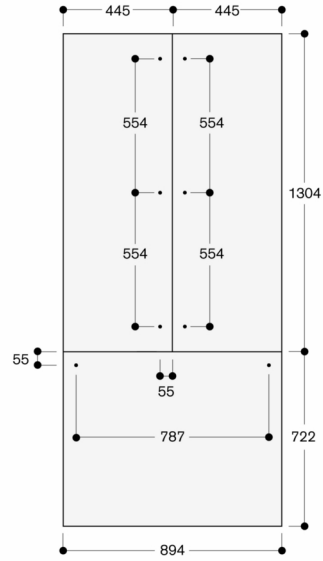

The door panel thickness is 19 mm

The maximum door panel dimensions are based on a clearance of 3 mm, based on a single niche

Measurements in mm

Niche width 900 mm

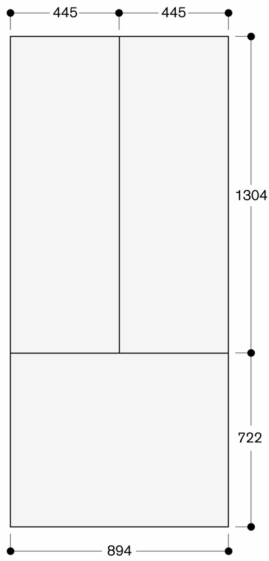

The door panel thickness is 19 mm

The maximum door panel dimensions are based on a clearance of 3 mm, based on a single niche

Measurements in mm

Replacement of side-by-side installation incl. RVY 497

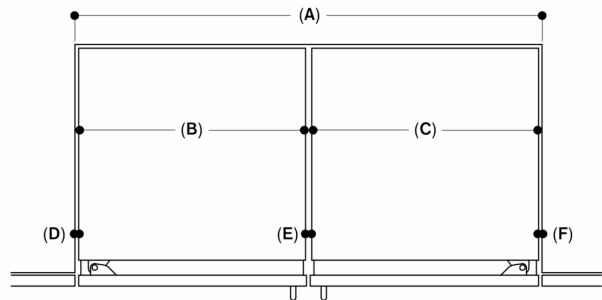

A: Niche width	1828	≤ 1676
B: Appliance 1 width	894	894
C: Appliance 2 width	894	≤ 756
D: Left gap	10	10
E: Center gap	20	13
F: Right gap	10	3

Measurements in mm

Replacement of side-by-side installation with Vario Cooling 400 series

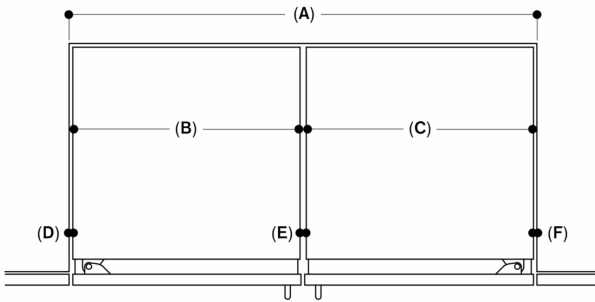

A: Niche width	1828	≤ 1676
B: Replacement appliance width	894	≤ 756
C: Vario Cooling 400 appliance width	≤ 908	≤ 908
D: Left gap	10	3
E: Center gap	13	6
F: Right gap	3	3

Measurements in mm

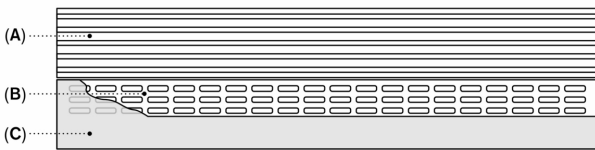

- A: Air inlets and exhaust air outlets
- B: Ventilation openings in skirting board area
- C: Skirting board

The height of the plinth can be reduced to 50 mm based on the standard installation height
 The skirting board height needs to be reduced to match the plinth height to allow for the additional ventilation

Replacement of RVY 497 into 914 mm niche

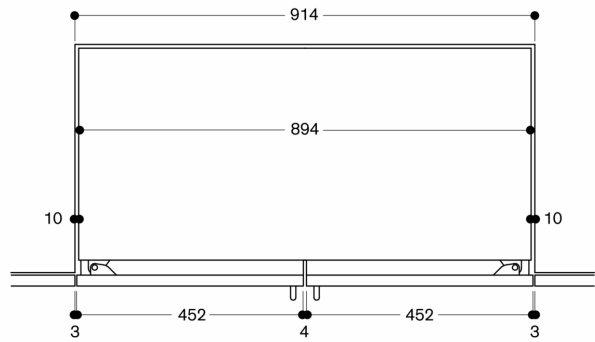

The resulting lateral gaps of 10 mm can be covered with side trims included in the installation accessory RVA 460 910

Measurements in mm

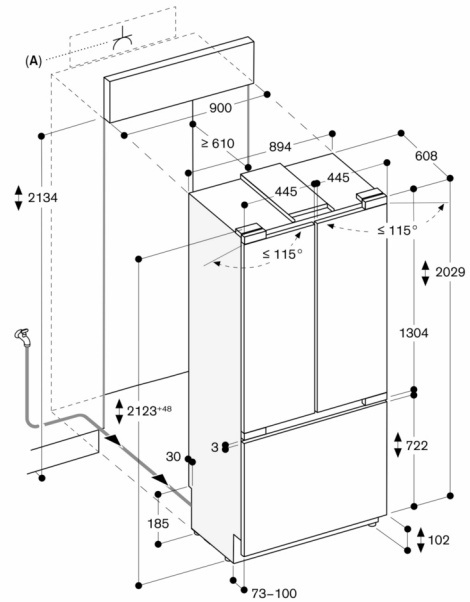

A: Socket

The maximum door panel dimensions are based on a clearance of 3 mm

The height of the plinth can be reduced to 50 mm

Measurements in mm

Plinth area

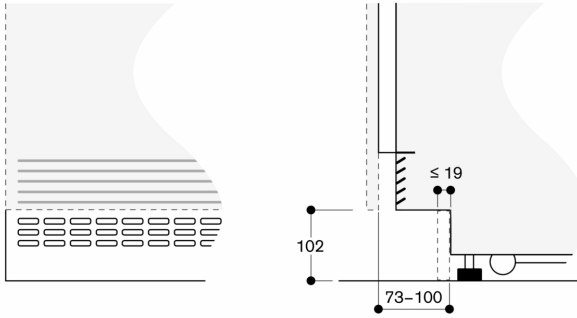

Based on the standard installation height, the height of the plinth is 102 mm

The height of the plinth can be reduced to 50 mm

Maximum skirting board thickness 19 mm

Measurements in mm

Wall clearance fridge-freezer combination

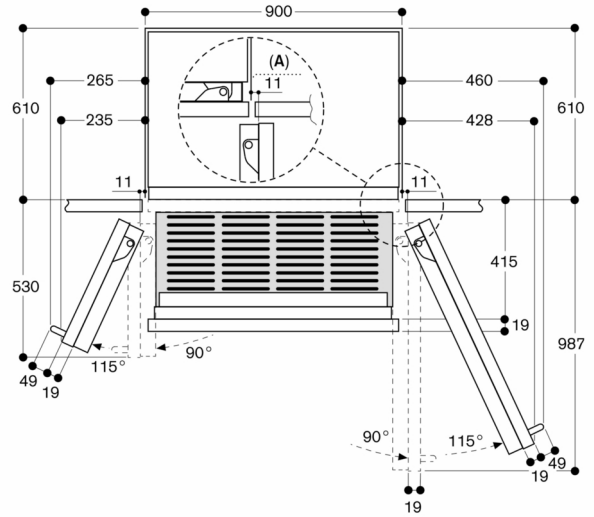

A: Recess

The clearances are based on a door panel thickness of 19 mm and a Gaggenau handle with a height of 49 mm

Measurements in mm

Installation niche for an individual appliance

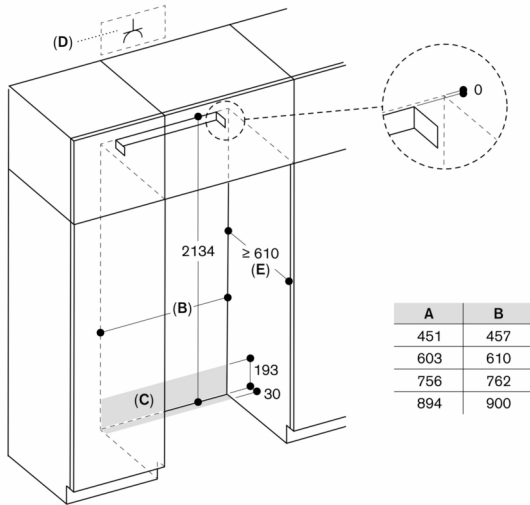

- A: Appliance width
- B: Width of installation niche
- C: Area for guiding water supply hose
- D: Socket
- E: Depth of installation niche, depending on kitchen design

Measurements in mm

Door opening angle

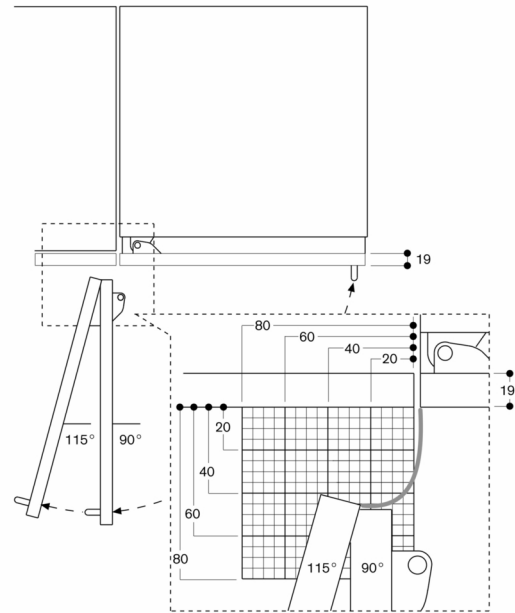

The hinge travel and resulting clearances from adjacent furniture units and handles can be found from the drawing while allowing for the thickness of the front panel. In the drawing, a furniture unit front panel thickness of 19 mm was assumed.