

## KIR37N2

37CM ISLAND CYLINDRICAL RANGEHOOD

MADE IN ITALY

Since 1948



### PRACTICAL YET STYLISH VENTING

Enhancing kitchen aesthetics whilst delivering exceptional functionality, the Smeg cylindrical rangehoods are a popular choice for providing effective air extraction to island kitchen benches and other appliances away from the wall.

### POWERFUL AIR EXTRACTION

Smeg's rangehoods have been developed to optimise performance for all cooking styles and kitchen designs. Careful research and development ensures that Smeg rangehoods are super quiet with maximum extraction performance. These models offer the highest possible performance for extreme cooking conditions, whilst remaining a stunning focal point in the kitchen.

### LOW NOISE

The design of the fan, motor and housing contribute to streamlined airflow which reduces noise levels during operation, for a more peaceful kitchen environment.

### INTENSIVE FUNCTION

Operate the hood at maximum power with the Intensive function, helping to speed up the elimination of the most persistent odours.

### DELAY FUNCTION

The Delay function ensures quick and efficient extraction of residual smoke, moisture and grease particles in the air after cooking.

#### RANGEHOOD FEATURES

EAN	8017709346096
Dimensions	370mm diameter x 870mmH
Finish	Black painted stainless steel
Hood type	Cylindrical
Installation	Island
Motor	1 x 250W
Max airflow	700m <sup>3</sup> /h (IEC 61591)
Noise rating	48 - 69 dB(A) (IEC 60704-2-13)
Illumination	2 x 1W LED
Dimmer mode	Yes
Light colour temperature	4000° K
Speeds	3 + intensive
Intensive speed	Yes
Control	LED back-lit electronic buttons
Supplied accessories	1 x aluminium anti-grease filter
Ducting Options	Duct to atmosphere or recirculate — 1 x 150mm diameter ducting required
Power	220 – 240V, 50 – 60Hz
Warranty	Five years parts and labour

	EXTRACTION RATE IEC 61591 [m <sup>3</sup> /h]	NOISE LEVEL IEC 60704-2-13 [dB(A)]
Speed 1	280	48
Speed 2	400	56
Speed 3	570	65
Intensive Speed	700	69

**KIR37N2**  
37CM ISLAND CYLINDRICAL RANGEHOOD

MADE IN ITALY  
Since 1948



Dimensions	370mm diameter x 870mmH
Power	220 – 240V, 50 – 60Hz
Warranty	Five years parts and labour

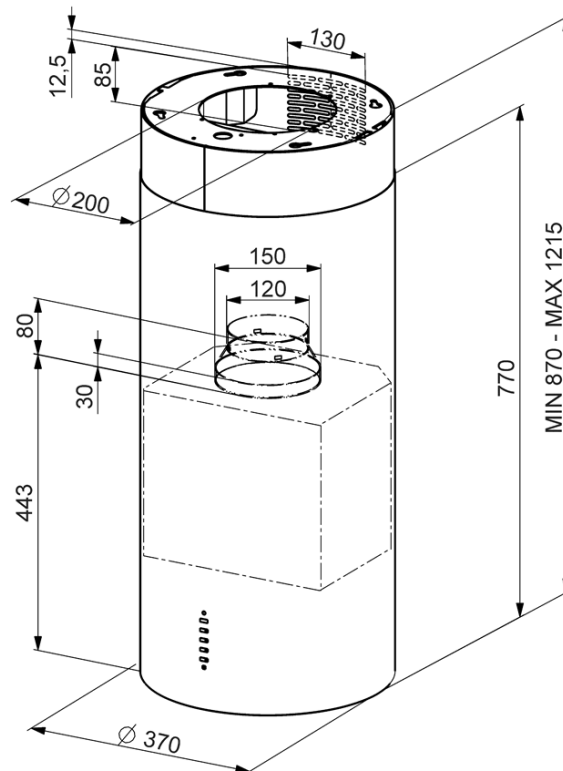

PLEASE NOTE: drawings are not to scale. They are to assist only.

WARNING: technical specifications and product sizes can be varied by the manufacturer without notice.

Cutouts for appliances should only be by physical product measurements. The above information is indicative only.