

SL83 FRESCO 1500

150MM FRESCO HOOD



let's get
Sirius
with rangehood design



SL83 FRESCO 1500

Features and Benefits:

ALFRESCO HOODS	Specially designed for outdoor under-cover use, custom built high power motors, minimises smoke and odours from entering adjoining living areas
HALOGEN LIGHTING	Energy efficient, Better illumination of cooking area, Longer life span than standard globes, Modern aesthetic
25MM COMMERCIAL STAINLESS STEEL BAFFLE FILTERS	Commercial design, Dishwasher safe, Designed for greatest air movement for maximum performance, Easy to fit and remove, Lifetime filters: last the life of the hood
INDUCTION COUNTDOWN	10 minute auto function used at the end of cooking to reduce condensation build up common to induction cooking. 'C' shaped baffles eliminates moisture dripping onto cooking surface
LARGER DUCTING DIAMETER	300mm -Greater extraction and lower dB rating due to less air flow restriction
CLEAN FILTER INDICATOR	Takes the guessing game out of maintaining your hood

Distributed by Arisit Pty Ltd

40-44 Mark Anthony Drive, Dandenong South VIC 3175 Ph: 1300 762 219 Fax: 03 9768 0838 Website: www.arisit.com

SL83 FRESCO 1500

150MM FRESCO HOOD



let's get
Sirius
with rangehood design

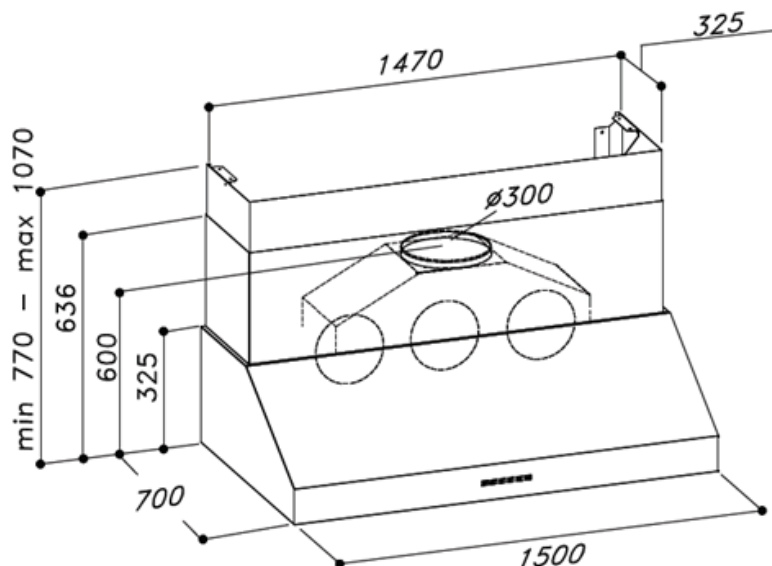

Technical Specifications:

MODEL	SL 83 FRESCO 1500
CONTROL PANEL	ELECTRONIC CONTROL
MOTOR	TRIPLE ALUMINIUM EBM
EXTRACTION	3060m/3h
DUCTING DIAMETER	300mm
LIGHTS	5 x ADJUSTABLE
FILTER	25mm COMMERCIAL STAINLESS STEEL FILTER
ELECTRICAL REQUIREMENT	10A
PRODUCT DIMENSIONS	1500 x 700 x 770-1070

WARNING: technical specifications and product sizes can be varied by the manufacturer, without notice. Cut outs for appliances should only be by physical product measurements. The above information is indicative only.

Distributed by Arisit Pty Ltd

40-44 Mark Anthony Drive, Dandenong South VIC 3175 Ph: 1300 762 219 Fax: 03 9768 0838 Website: www.arisit.com