

SL906 L-520
52CM CANOPY HOOD



let's get
Sirius
 with rangehood design



SL906 L-520

Features and Benefits:

UNDERMOUNT DESIGN	Streamline, modern and unobtrusive design, potentially allows greater use of cupboard space above hob- Fits into Standard 300mm cabinetry
LED LIGHTS	Energy efficient, Better illumination of cooking area, Longer life span than standard globes or Halogen, Modern aesthetic
25MM COMMERCIAL STAINLESS STEEL BAFFLE FILTERS	Commercial design, Dishwasher safe, Designed for greatest air movement for maximum performance, Easy to fit and remove, Lifetime filters: last the life of the hood
INDUCTION COUNTDOWN CONTROL	10 minute auto function used at the end of cooking to reduce condensation build up common to induction cooking. 'C' shaped baffles eliminates moisture dripping onto cooking surface
LARGER DUCTING DIAMETER	Greater extraction and lower dB rating due to less air flow restriction
CLEAN FILTER INDICATOR	Takes the guessing game out of maintaining your hood
MADE IN ITALY	Units are designed specifically for the Australian market and manufactured in Italy by dedicated boutique specialist manufacturer

Distributed by Arisit Pty Ltd

40-44 Mark Anthony Drive, Dandenong South VIC 3175 Ph: 1300 762 219 Fax: 03 9768 0838 Website: www.arisit.com

SL906 L-520

52CM CANOPY HOOD



let's get
Sirius
with rangehood design

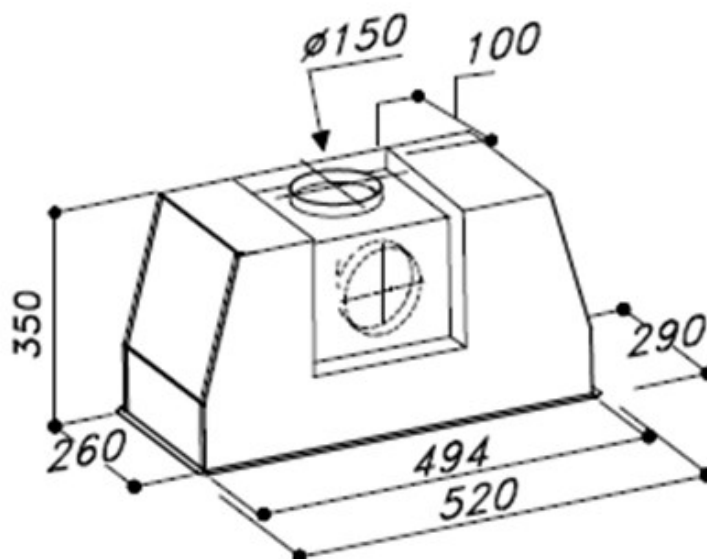

Technical Specifications:

MODEL	SL906 L-520
CONTROL PANEL	ELECTRONIC BUTTON CONTROL
MOTOR	SINGLE ALUMINIUM
EXTRACTION	1020m/3h
DUCTING DIAMETER	150mm
LIGHTS	6w strip LED Lighting
FILTER	25mm STAINLESS STEEL BAFFLE
ELECTRICAL REQUIREMENT	10A
PRODUCT DIMENSIONS	520 x 290 X 350

WARNING: technical specifications and product sizes can be varied by the manufacturer, without notice. Cut outs for appliances should only be by physical product measurements. The above information is indicative only.

Distributed by Arisit Pty Ltd

40-44 Mark Anthony Drive, Dandenong South VIC 3175 Ph: 1300 762 219 Fax: 03 9768 0838 Website: www.arisit.com