

Integrated Single DishDrawer™ Dishwasher, Sanitise

Series 9 | Integrated

Panel Ready



Integrating into your kitchen design seamlessly, each drawer fits a half load that you can load and wash independently.

- Knock to pause function is perfect if you miss a dish
- Six wash programs, as well as additional Quick wash, Sanitise and Extra Dry options
- Customise with your own front panel and handle to match your kitchen cabinetry

DIMENSIONS

Height	410mm
Width	599mm
Depth	571mm

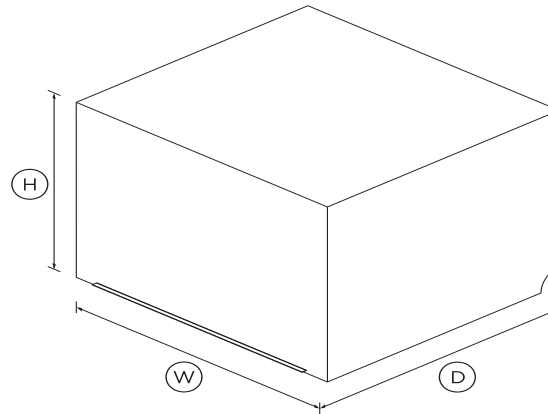

FEATURES & BENEFITS

Ease of use

DishDrawer™ Dishwashers are as easy to open and close as kitchen drawers and can be conveniently positioned at bench height for ease of loading and minimal bending.

Quick, Sanitise and Extra Dry options

The Quick wash modifier delivers a faster wash while maintaining performance. The Sanitise option provides extra protection, killing 99.9% of bacteria in the final rinse. The Extra Dry setting is perfect for plastic dishes.

Knock to pause

Instead of needing a remote control, these DishDrawer™ Dishwashers have a knock to pause function. A double knock on the front panel will pause the dishwasher which can be re-started again by using the start/play button.

Quiet performer

Running at a very low decibel rate, these DishDrawer™ Dishwashers do their job without making a fuss. The combination of intelligent technology and simple mechanics means greater reliability and excellent wash performance.

SPECIFICATIONS

Accessories

- Cutlery basket
- Knife clip and multipurpose

Capacity and loading

- Accommodates round plates **280mm**
- Adjustable height, foldable
- Fold down tines
- Pitch adjustable tines

Consumption

- Energy rating **3.5 star**

Controls

- Child lock
- Electronic fault/Diagnostic
- End of cycle beeps
- Energy saving delay start
- Internal wash selector

- Knock to pause
- Rinse aid indicator light

Features

- Fan assisted drying
- Flow through detergent
- Quiet operation
- SmartDrive™ technology

Performance

Noise on standard cycle top **43dBA**

Power requirements

Amperage **4.2A**

Product dimensions

Depth **571mm**
 Height **410mm**
 Width **599mm**

Warranty

Parts and labour **2 years**

Wash Program Modifiers

- Extra Dry
- Quick
- Sanitise

Wash Programs

- Delicate
- Eco
- Fast
- Heavy
- Medium
- Rinse

Water connection

Water pressure **0.1 Mpa - 1 Mpa**

SKU **81211**

The product dimensions and specifications in this page apply to the specific product and model. Under our policy of continuous improvement, these dimensions and specifications may change at any time. You should therefore check with Fisher & Paykel's Customer Care Centre to ensure this page correctly describes the model currently available. ? Fisher & Paykel Appliances Ltd 2020

Other product downloads available at fisherpaykel.com

- [↓](#) Service & Warranty
- [↓](#) Quick Start Guide
- [↓](#) User Guide
- [↓](#) Energy Label
- [↓](#) Installation Guide
- [↓](#) Specification Guide SingleDishDrawer
- [↓](#) Data Sheet Integrated Single DishDrawer



A PEACE OF MIND SALE

24 Hours 7 Days a Week Customer Support

T 1300 650 590 Wwww.fisherpaykel.com