

# CG905DX1 90CM

## 5 BURNER GAS ON STEEL GAS COOKTOP

Create mouth watering dishes with ease. Linear cast iron trivets make it easier to move pots and pans between elements.



<b>MODEL</b>	<b>CG905DX1</b>
<b>Burners</b>	5 including 1 wok burner
<b>Dimensions</b>	H59 x W900 x D530mm
<b>FEATURES</b>	<b>BENEFITS</b>
Cast Iron Trivets	Exceptionally durable with rubber grommets, the cast iron trivets provide a stable cooking surface, allowing for easy transfer of pots and pans, as well as being long lasting and easy to clean.
Electronic Ignition	Easy ignition and accurate temperature control, ergonomic dials automatically ignite the flame when the control dial is pushed down and turned around to its desired setting.
Quick Connect Gas Valve	The quick connect gas valves are twice as fast and more reliable than conventional gas valves. Time holding the dial down to ignite the flame is halved.
Flame Failure Safety Device	This reassuring safety feature ensures that gas will not continue to be supplied when there is no flame. If the flame is blown out then the gas to the burner is cut off.
Spill Containment	An important safety feature that protects the user and cooktop surrounds from hot spillages of up to 2L.
Triple Ring Wok Burner	A large and powerful burner with a maximum output of 16.6 MJ/h, the wok burner is great for foods that require a high heat.
Burner Ratings (Shown for Natural Gas) LPG convertible	0.9-3.6 MJ/h Auxiliary burner 8.4 MJ/h Semi-rapid burners 16.6 MJ/h Wok burner 11.5 MJ/h Rapid burner

<b>DIMENSIONS</b>	<b>MM</b>
Ⓐ Overall height of chassis (below top of bench)	59
Ⓑ Overall width of product	900
Ⓒ Overall depth of product	530

For further details about sizes please refer to the installation manual.

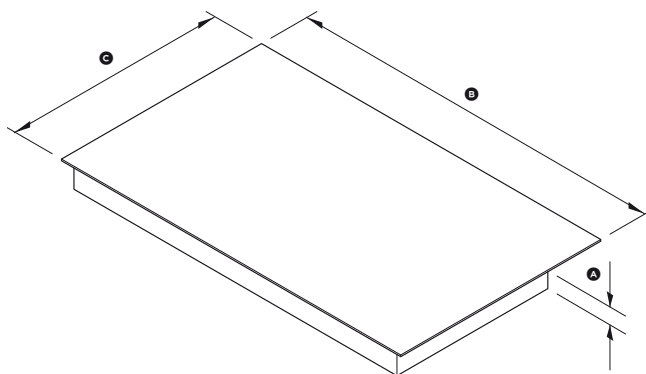

24 HOURS  
7 DAYS A WEEK  
CUSTOMER  
SERVICE